**COSPAS-SARSAT
GEOLUT
PERFORMANCE SPECIFICATION
AND DESIGN GUIDELINES**

C/S T.009
Issue 1 Revision 8
October 2012



COSPAS-SARSAT GEOLUT
PERFORMANCE SPECIFICATION AND DESIGN GUIDELINES

History

<u>Issue</u>	<u>Revision</u>	<u>Date</u>	<u>Comments</u>
1	0	October 1998	Approved (CSC-21)
1	1	October 1999	Approved (CSC-23)
1	2	October 2002	Approved (CSC-29)
1	3	October 2004	Approved (CSC-33)
1	4	November 2005	Approved (CSC-35)
1	5	October 2006	Approved (CSC-37)
1	6	October 2008	Approved (CSC-41)
1	7	October 2009	Approved (CSC-43)
1	8	October 2012	Approved (CSC-49)

TABLE OF CONTENTS

		Page
1.	INTRODUCTION	1-1
1.1	Overview	1-1
1.2	Scope.....	1-1
1.3	Document Organisation	1-1
1.4	Reference Documents	1-1
2.	COSPAS-SARSAT GEOLUT DESCRIPTION	2-1
3.	OPERATIONAL REQUIREMENTS	3-1
3.1	GEOLUT Data Availability.....	3-1
3.2	Data Requirements.....	3-1
3.3	Satellite Tracking Capability	3-1
3.4	Satellite Visibility	3-1
3.5	Status and Alarm Reporting.....	3-2
3.6	RF Radiation and Emissions.....	3-2
3.7	Interference	3-2
3.8	Data Archiving.....	3-2
3.9	Cospas-Sarsat Quality Management System (QMS) Continuous Monitoring and Objective Assessment	3-2
4.	FUNCTIONAL AND PROCESSING REQUIREMENTS.....	4-1
4.1	Functional Requirements	4-1
4.1.1	Antenna and RF Subsystem	4-1
4.1.2	Time and Frequency Reference Subsystem.	4-1
4.1.3	MCC Interface.....	4-1
4.2	Processing Requirements	4-1
4.2.1	General Processing Requirements.....	4-1
4.2.2	406 MHz Beacon Message Recovery	4-2
4.2.3	Bit Verification.....	4-2
4.2.4	Beacon Message Validation.....	4-3

4.2.5	Beacon Message Processing	4-4
4.2.5.1	Confirmed Beacon Messages	4-4
4.2.5.2	Unconfirmed Short Message Format.....	4-4
4.2.5.3	Unconfirmed Long Message Format	4-5
4.2.6	Redundant Alert Data.....	4-5
4.2.7	Updated Location Data	4-5
4.2.8	Bit-Shifted Beacon Messages	4-5
4.2.9	Special National Processing Requirements.....	4-5
5.	PERFORMANCE REQUIREMENTS.....	5-1
5.1	Processing Performance	5-1
5.2	Frequency Measurement	5-1
5.3	Capacity	5-1
5.4	Processing Anomaly Rate	5-2
5.5	Downlink Fading	5-2

LIST OF FIGURES

Figure 2.1:	A Typical Cospas-Sarsat GEOLUT Functional Block Diagram.....	2-1
-------------	--	-----

LIST OF ANNEXES

Annex A:	GEOSAR Space System Performance Parameters and Downlink Budgets
----------	---

1. INTRODUCTION

1.1 Overview

The purpose of the Cospas-Sarsat System is to provide distress alert and location data for search and rescue (SAR), using spacecraft and ground facilities to detect and locate the signals of Cospas-Sarsat distress radiobeacons operating on 406 MHz and/or 121.5 MHz. An earth receiving station in the Cospas-Sarsat System which receives and processes 406 MHz signals relayed by a geostationary satellite is called a GEOSAR Local User Terminal (GEOLUT). The GEOLUT transmits alert and location data to the associated Cospas-Sarsat Mission Control Centre (MCC) for subsequent distribution to SAR authorities.

For acceptance as part of the Cospas-Sarsat System, a GEOLUT shall be commissioned as defined in the document C/S T.010, Cospas-Sarsat GEOLUT Commissioning Standard, to verify compliance of its performance with this specification.

1.2 Scope

This specification describes the minimum operational capabilities and performance requirements of a Cospas-Sarsat GEOLUT. The specifications in this document apply to data transmitted by a GEOLUT for distribution in the Cospas-Sarsat MCC network.

1.3 Document Organisation

A brief description of a GEOLUT is provided in section 2. Section 3 defines basic GEOLUT operational requirements, functional and processing requirements are provided in section 4, and section 5 contains specific performance requirements for a GEOLUT.

The annex to this document contains reference information for GEOLUT operators and designers.

1.4 Reference Documents

The latest version of the following documents contain useful information describing the signals to be received by a GEOLUT (references a, d and f), and defining how a GEOLUT is integrated into the Cospas-Sarsat System:

- a. C/S T.001, Specification For Cospas-Sarsat 406 MHz Distress Beacons;
- b. C/S T.002, Cospas-Sarsat LEOLUT Performance Specification and Design Guidelines;
- c. C/S T.005, Cospas-Sarsat LEOLUT Commissioning Standard;
- d. C/S T.006, Cospas-Sarsat Orbitography Network Specification;

- e. C/S T.010, Cospas-Sarsat GEOLUT Commissioning Standard;
- f. C/S T.011, Description of the 406 MHz Payloads Used in the Cospas-Sarsat GEOSAR System;
- g. C/S A.001, Cospas-Sarsat Data Distribution Plan (DDP);
- h. C/S A.002, Cospas-Sarsat Mission Control Centres Standard Interface Description (SID); and
- i. C/S A.005, Cospas-Sarsat Mission Control Centre Performance Specification and Design Guidelines.

-END OF SECTION 1-

2. COSPAS-SARSAT GEOLUT DESCRIPTION

A GEOLUT is a ground receiving station in the Cospas-Sarsat System that detects, processes, and recovers the coded transmissions of 406 MHz emergency beacons, and relays the appropriate information to an MCC. It processes this data which has been modulated onto a single downlink carrier by a Geostationary Search And Rescue (GEOSAR) satellite. The technical parameters of the various GEOSAR satellites are described in detail in document C/S T.011 (description of GEOSAR payloads).

A GEOLUT is defined in this document as a function. It may be implemented in many ways, such as sharing equipment or software with a LEOLUT or an MCC. However, an implementation based on sharing equipment or software must meet the data availability requirements specified in this document.

A GEOLUT consists of at least the following basic components and interfaces:

- a. an antenna and radio frequency subsystem;
- b. a processor;
- c. a time and/or frequency reference subsystem; and
- d. an MCC interface.

A typical Cospas-Sarsat GEOLUT functional block diagram is shown in Figure 2.1.

GEOSAR SATELLITE
DOWNLINK SIGNAL

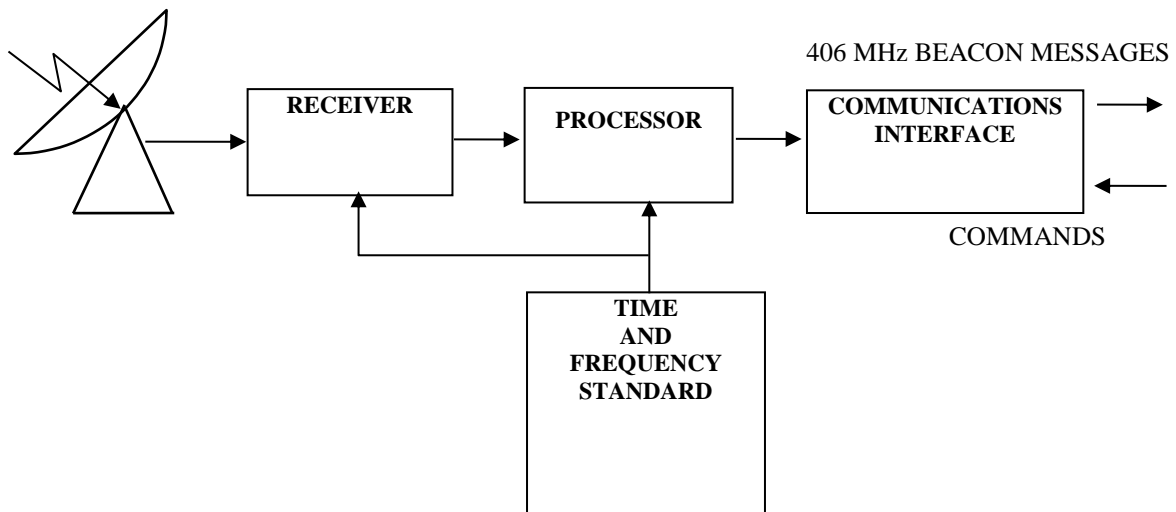

Figure 2.1: A Typical Cospas-Sarsat GEOLUT Functional Block Diagram

The SAR instruments on Cospas-Sarsat GEOSAR satellites receive uplink signals from 406 MHz distress beacons, test beacons and system beacons such as orbitography beacons. These uplink signals, along with unwanted interfering signals, are relayed by the GEOSAR satellite for reception by a GEOLUT.

A Cospas-Sarsat GEOLUT shall process the GEOSAR downlink signal to produce 406 MHz GEOSAR alerts, including the associated location data when available in the beacon message, and forward this information to the associated MCC for further action.

The operational, functional and performance specifications of this document must be met to ensure that:

- a) the GEOLUT is available and capable to receive and process beacons signals in the GEOSAR downlink signal; and
- b) the GEOLUT provides reliable alerts and accurate position data by:
 - i) detecting invalid 406 MHz beacon messages and processing them in accordance with this specification,
 - ii) verifying whenever possible that data formats are correct and encoded data is valid, including the beacon identification and encoded position information, and
 - iii) providing updated position information to the MCC, as appropriate.

A GEOLUT may be used to supply data from a geostationary satellite to improve the quality of the solution data for 406 MHz beacons which are detected and located by a LEOLUT.

-END OF SECTION 2-

3. OPERATIONAL REQUIREMENTS

The basic operational objective of a GEOLUT is to receive and process data from a selected GEOSAR satellite and to send the resulting 406 MHz beacon messages to the associated MCC, according to the functional and performance specifications contained in this document. Once the GEOLUT has been commissioned and connected to the Cospas-Sarsat network through an MCC, it shall continue to meet the operational, functional and performance specifications of this document.

3.1 GEOLUT Data Availability

A GEOLUT commissioned for operation within the Cospas-Sarsat system, shall provide data to the associated MCC twenty-four (24) hours a day, seven (7) days a week with less than five percent (5%) downtime calculated over a year. Outages of the GEOSAR satellite to GEOLUT downlink signal due to propagation effects shall be included in the computation of the GEOLUT's availability. However, outages of the GEOSAR satellite itself and seasonal outages due to increased noise levels when the GEOSAR satellite transits the sun shall be excluded from the calculation.

3.2 Data Requirements

The GEOLUT shall provide all data necessary for the MCC to distribute relevant beacon alert data to the appropriate Search and Rescue Point of Contact (SPOC), according to the document C/S A.002 (SID).

3.3 Satellite Tracking Capability

The GEOLUT shall be capable of continuously receiving the downlink signal from at least one GEOSAR satellite of the type described in document C/S T.011, Description of the 406 MHz Payloads Used in the Cospas-Sarsat GEOSAR System. The GEOLUT shall be capable of detecting and processing beacon signals in the entire uplink bandwidth that is used by the selected GEOSAR satellite for operational 406 MHz beacons. The GEOLUT shall be capable of operating without degradation in all operational modes of the selected GEOSAR satellite.

The GEOLUT shall be capable of processing all data from a GEOSAR satellite without significant degradation or loss due to relative satellite motion caused by orbit eccentricity and inclination.

3.4 Satellite Visibility

It is recommended that GEOLUTs operate with GEOSAR satellites that have elevation angles at least 5 degrees above the local horizon. If the GEOLUT must operate at an elevation angle lower than 5 degrees, the GEOLUT should be equipped with a receive antenna with

appropriate gain and beamwidth to avoid the unnecessary introduction of background noise into the GEOLUT's receiver system.

3.5 Status and Alarm Reporting

The GEOLUT shall provide the MCC with sufficient status and alarm information to permit the MCC to determine the degradation of its operational capabilities.

3.6 RF Radiation and Emissions

The GEOLUT shall not emit or radiate any Radio Frequency (RF) signals which will interfere with the proper functioning of the Cospas-Sarsat System or other authorized users of the electromagnetic spectrum.

3.7 Interference

The GEOLUT should be designed to operate with minimal degradation or loss of data in the presence of interference in the beacon to GEOSAR uplink signal, the GEOSAR to GEOLUT downlink signal, and in the local GEOLUT's site environment.

3.8 Data Archiving

The GEOLUT shall maintain access to the data elements listed below for a period of at least three months:

- a. the 36 hexadecimal character representation of each 406 MHz beacon burst received;
- b. the frequency and time measurement of each 406 MHz beacon burst received;
- c. the C/No ratio for each 406 MHz beacon burst received;
- d. the 36 hexadecimal character representation of all valid and confirmed 406 MHz beacon alerts provided to the MCC;
- e. the frequency, date/time, C/No ratio, and number of independent integrations for all valid and confirmed 406 MHz beacon alerts provided to the MCC;
- f. power spectrum data for 406 MHz interferers detected by the GEOLUT; and
- g. the log files that capture the status of the GEOLUT.

3.9 Cospas-Sarsat Quality Management System (QMS) Continuous Monitoring and Objective Assessment

The GEOLUT shall transmit solution data to its associated MCC as required by the QMS continuous monitoring and objective assessment process described in section 9 of C/S A.003.

4. FUNCTIONAL AND PROCESSING REQUIREMENTS

The basic functional and processing requirements of a GEOLUT are to:

- a. acquire and receive the downlink signal from the selected GEOSAR satellite(s);
- b. maintain time and frequency references;
- c. process and recover 406 MHz beacon messages; and
- d. provide the appropriate data to the associated MCC to enable the MCC to satisfy the requirements of document C/S A.002 (SID).

4.1 Functional Requirements

4.1.1 Antenna and RF Subsystem

The GEOLUT's antenna and RF subsystem shall be able to acquire and continuously receive the downlink signal from the GEOSAR satellite(s) with which the GEOLUT is required to operate. GEOLUTs operating with GEOSAR satellites that have 1544.5 MHz downlink frequencies should use right hand circular polarisation (RHCP) receive antennas to reduce the potential for interference from LEOSAR satellite downlink signals. However, linearly polarised antennas are acceptable for satellites that have linearly polarised downlinks.

4.1.2 Time and Frequency Reference Subsystems

The GEOLUT system time shall be maintained to within ten (10) milliseconds of universal co-ordinated time (UTC). Additionally, it is recommended that the frequency reference for all applicable local oscillators should have a stability of five parts in ten raised to the power of nine, over fifteen minutes.

4.1.3 MCC Interface

The GEOLUT must provide timely information of the level of quality and detail specified in the documents C/S A.002 (SID) and C/S A.005 (MCC specification).

4.2 Processing Requirements

4.2.1 General Processing Requirements

The GEOLUT shall process 406 MHz beacon messages as described in this section. The GEOLUT shall process all available information and provide, as appropriate, encoded position data or unlocated alerts. The processing consists of the following

sequence: message recovery, bit verification, message validation, message processing and transmission of resultant alert data to the associated MCC.

4.2.2 406 MHz Beacon Message Recovery

The GEOLUT must recover 406 MHz digital bursts relayed by the selected GEOSAR satellite. Successive bursts of the same transmitting beacon can be integrated until a valid message is produced.

The GEOLUT shall process and transmit to the associated MCC only beacon messages that achieve a perfect match of bits 16 to 24 with the 9 bit frame synchronisation pattern described in the document C/S T.001 (Beacon Specification).

If a valid message (section 4.2.4 refers) cannot be produced by the GEOLUT within twenty (20) minutes from the time of reception of the first burst of the current integration process, the GEOLUT integration process must be halted, reset, and restarted for that particular beacon message.

The GEOLUT may also record for off-line processing “self-test” mode beacon messages that have an inverted frame synchronisation pattern. However, such data shall not be used in the processing of operational alerts.

4.2.3 Bit Verification

The GEOLUT shall detect and correct as follows, bit errors in the 406 MHz beacon messages.

The digital message transmitted by 406 MHz beacons includes a 21-bit BCH error correcting code, and, in the long message format, an additional 12-bit BCH error correcting code (except as noted below). The GEOLUT shall use these BCH codes to verify and correct as necessary the received 406 MHz beacon messages. All beacon messages include the following fields:

- first protected data field (PDF-1, bits 25 to 85) which contains the beacon identification and can include position data; and
- first BCH error correcting field (BCH-1, bits 86 to 106) which contains the 21-bit BCH error correcting code that protects the 82 bits of PDF-1 and BCH-1. The 82 bits of PDF-1 and BCH-1 are also referred to as the first protected field.

The long message format also includes:

- the second protected data field (PDF-2, bits 107 to 132) which contains position and supplementary data; and

- the second BCH error correcting field (BCH-2, bits 133 to 144) which contains the 12-bit BCH error correcting code that protects the 38 bits of PDF-2 and BCH-2. The 38 bits of PDF-2 and BCH-2 are also referred to as the second protected field.

The GEOLUT shall use BCH-1 to correct all messages that have a maximum of three bit errors in the first protected field, and detect the existence of more than three (3) errors with a probability of 95%. The GEOLUT shall use BCH-2 to correct any messages that have one bit error in the second protected field of the long message format and to detect the existence of two or more bit errors. When the GEOLUT determines there are 2 or more bit errors in the second protected field, bits 113 to 144 shall all be replaced with “1”. The GEOLUT shall set bits 113 to 144 all to “0” for short format beacon messages.

The GEOLUT shall have the capability to suppress all orbitography and calibration beacon messages, and pass them to the MCC only on request. The long version of the orbitography protocol (bits 37-39 = “000”) messages are processed differently from other protocol messages in respect to verification of bits 107 to 144 and are not subject to message validation defined in 4.2.4. While the short message portion (bits 25-106) is error corrected by BCH-1, there is no error correction and detection applicable to bits 107 to 144. The GEOLUT shall send the uncorrected data in bits 107 to 144 to the associated MCC.

As defined in document C/S T.001, Specification for Cospas-Sarsat 406 MHz Distress Beacons, Standard location protocol beacon messages contain fixed values of “1101” in bits 107-110 and National location protocol beacon messages contain fixed values of “110” in bits 107-110. These fixed bits, which immediately follow BCH-1, are used to identify a beacon message that is corrupted due to bit-shift errors, in case the bit-shifted beacon message passes BCH-1 error detection. After using the BCH-1 and BCH-2 to correct bit errors in the 406 MHz beacon message (as defined above), the GEOLUT shall verify the fixed bits that begin in bit 107 for location protocol beacons (i.e., bits 107-110 for Standard location protocol beacons and bits 107-109 for National location protocol beacons).

4.2.4 Beacon Message Validation

A 406 MHz beacon message is valid when the first protected field (PDF-1 + BCH-1) has 2 or less corrected bit errors and the fixed bits that start in bit 107 contain no errors.

A complete message consists of :

- the first protected field (PDF-1 + BCH-1) of a valid short message; or
- the first and second protected fields (PDF-1 + BCH-1 + PDF-2 + BCH-2) of a valid long message where the second protected field contains no errors or 1 corrected bit error.

Bits 113 to 144 of the second protected field of a valid long message shall all be set to “1” if this field contains 2 or more bit errors.

4.2.5 Beacon Message Processing

406 MHz alert data recovered by the GEOLUT shall be transmitted to the associated MCC for distribution to the relevant RCC as provided for in the document C/S A.001 (DDP). The GEOLUT shall confirm the validity of GEOSAR alert data whenever possible, and process beacon messages in accordance with the principles described below.

4.2.5.1 Confirmed Beacon Messages

The GEOLUT shall transmit to the MCC complete messages confirmed in accordance with the following rules:

- a. the first protected field (PDF-1 + BCH-1) of a valid message is confirmed when the first protected data field (PDF-1) matches with the first protected data field of the second message obtained as a result of an independent integration process; and
- b. the second protected field (PDF-2 + BCH-2) of a complete message is confirmed when the second protected data field (PDF-2) matches with the second protected data field of the second message obtained as a result of an independent integration process.

The GEOLUT shall also transmit to the MCC valid but incomplete long messages as soon as the first protected field (PDF-1 + BCH-1) is confirmed as described above. In this case bits 113 to 144 of the second protected fields shall all be set to “1”. If a complete long message is subsequently obtained with the same PDF-1 data and confirmed as described above, the confirmed complete message shall also be transmitted to the MCC.

4.2.5.2 Unconfirmed Short Message Format

If the confirmation of the first protected field of a valid short message is not achieved within five (5) minutes from the time of its validation, this message shall be transmitted to the MCC with the indication that it is unconfirmed.

If the confirmation of the first protected field of a valid short message is achieved after the transmission of the unconfirmed message, the confirmed message shall also be sent to the MCC.

4.2.5.3 Unconfirmed Long Message Format

If the confirmation of the first and second protected fields of a complete long message format is not achieved within five (5) minutes from the time of its validation, this message shall be transmitted to the MCC with bits 113 to 144 of the second protected field all set to “1”, and with the indication that it is unconfirmed.

If the confirmation of the first and second protected fields, or the confirmation of the first protected field only, are achieved after the transmission of an unconfirmed message, the confirmed complete, or confirmed incomplete, message shall also be sent to the MCC. Bits 113 to 144 of an incomplete message shall all be set to “1”.

4.2.6 Redundant Alert Data

Except for the data collected as part of the QMS continuous monitoring and objective assessment process, the GEOLUT shall suppress redundant data as required by the MCC.

4.2.7 Updated Location Data

The GEOLUT shall provide to the MCC, in accordance with the rules set forth in 4.2.5, the first location data acquired after the beacon has been turned on.

The GEOLUT shall then provide to the MCC only confirmed complete or confirmed incomplete beacon messages containing location data updated in accordance with the beacon specification document C/S T.001.

4.2.8 Bit-Shifted Beacon Messages

The GEOLUT shall not output to the MCC beacon messages which contain either complete or partial bit-shifted versions of the transmitted beacon identification code caused by incorrect bit synchronization by the GEOLUT to the beacon message's bit and frame synchronization pattern (bits 1 to 24).

4.2.9 Special National Processing Requirements

In order to satisfy special national requirements, the associated MCC may request a GEOLUT to transmit 406 MHz beacon alert messages which do not conform to the processing requirements of section 4.2. However, operational alert data distributed internationally shall always meet the requirements of section 4.2.

-END OF SECTION 4

5. PERFORMANCE REQUIREMENTS

The performance requirements defined in the following paragraphs establish measurable quantities that a GEOLUT must meet before it can be integrated into the Cospas-Sarsat System and commissioned by the Cospas-Sarsat Council.

5.1 Processing Performance

The GEOLUT shall be able to receive, detect, recover and provide to the associated MCC, valid messages within 5 minutes of beacon activation with a probability of 0.95, provided that:

- a. the beacon conforms to the coding and burst repetition specifications detailed in document C/S T.001;
- b. the beacon signal was not interfered with by another emitter in the GEOSAR satellite uplink field of view. For this particular requirement, interference is defined as any emitter whose radiated energy occupies both the same time and frequency as the individual bursts from the 406 MHz beacon; and
- c. the beacon uplink signal is linearly polarised and has a transmit EIRP of:
 - 32 dBm for GEOLUTs that operate with the MSG satellite,
 - 29 dBm for GEOLUTs that operate with the GOES satellites,
 - [TBD] dBm for GEOLUTs that operate with the INSAT satellite, and
 - 28.5 dBm for GEOLUTs that operate with the Electro-L satellite.

5.2 Frequency Measurement

Subject to the conditions described at section 5.1, and a beacon signal that completely conforms to the specifications of document C/S T.001, the GEOLUT shall measure frequency of beacon signals to an accuracy of 2 Hz.

Due to the potential instability of the beacon frequency at the time of beacon activation, the frequency measurement shall be based upon the most recent frequency data measured by the GEOLUT.

5.3 Capacity

The definition of capacity is provided in Cospas-Sarsat document C/S T.012 (406 MHz frequency management plan). The GEOLUT shall support a capacity of 20 active beacons in each 406 MHz channel.

5.4 Processing Anomaly Rate

The processing anomaly rate is the number of processing anomalies provided by the GEOLUT to the MCC divided by the total number of valid messages produced by the LUT. The GEOLUT shall include features, other than beacon message content validation, that reduce the processing anomaly rate to a minimum. The ratio of GEOLUT generated false alerts caused by processing anomalies to actual alerts shall not exceed 1×10^{-4} .

5.5 Downlink Fading

The GEOLUT performance shall be maintained during periods of fading of the GEOSAR to GEOLUT downlink channel as detailed in Annex A. The GEOLUT data availability specified in paragraph 3.1 shall include the contribution of downlink outages. The design of the RF subsystem shall be such that this overall availability is achieved considering the statistics of local rainfall and other downlink propagation impairments.

-END OF SECTION 5-

**ANNEXES TO
COSPAS-SARSAT
GEOLUT
PERFORMANCE SPECIFICATION
AND DESIGN GUIDELINES**

ANNEX A**GEOSAR SPACE SYSTEM PERFORMANCE PARAMETERS
AND DOWNLINK BUDGETS****A.1 INTRODUCTION**

Administrations intending to acquire a GEOLUT to be used in the Cospas-Sarsat System should ensure that the station's antenna and RF subsystems will meet the Cospas-Sarsat performance standards defined in documents C/S T.009 and C/S T.010. One way to determine this performance is to calculate the downlink power budget for the applicable GEOSAR satellite that the GEOLUT will track. This annex provides guidance for making these calculations. If the GEOLUT will be capable of tracking different types of GEOSAR satellites, then these calculations should be completed for each type of satellite used.

A.2 EXPLANATION OF THE DOWNLINK BUDGET

TBD Information for the completion of this section will need to be provided by the applicable GEOSAR space segment providers. A separate description will be needed for each type of GEOSAR satellite. This information could be placed either here or in document C/S T.011 (description of GEOSAR payloads).

A.3 CALCULATIONS

TBD Information for the completion of this section will need to be provided by the applicable GEOSAR space segment providers. A separate description will be needed for each type of GEOSAR satellite. This information could be placed either here or in document C/S T.011 (description of GEOSAR payloads).

GEOSAR Search and Rescue Repeater Link Budget - Nominal Link

	<u>GOES</u>	<u>MSG</u>	<u>INSAT</u>
Beacon EIRP (Linear Pol.)	7 dBW	7 dBW	
Path Loss (5 Degree Elevation)	176.9 dB	176.9 dB	(TBD)
Polarization Loss	4.1 dB	5.0 dB	
Spacecraft G/T	-18.5 dB/K	-19.5 dB/K	
Boltzmann's Constant	-228.6 dBW/KHz	-228.6 dBW/KHz	
Uplink C/No	36.1 dB-Hz	34.2 dB-Hz	
Transmit EIRP	15 dBW		

	<u>GOES</u>	<u>MSG</u>	<u>INSAT</u>
Modulation Loss (1.0 Rad)	2.0 dB		
Power Sharing Loss (80 Khz BW)	13.1 dB		
Transmit EIRP per Beacon	-0.1 dBW	-15.1 dBW	
Path Loss (5 Degree Elevation)	188.5 dB	188.5 dB	
Polarization Loss	0.3 dB	0.3 dB	
Boltzmann's Constant	-228.6 dBW/KHz	-228.6 dBW/KHz	
Ground Station G/T	11 dB/K	14.5 dB/K	
Downlink C/No	50.7 dB-Hz	39.2 dB-Hz	
Composite C/No	36.0 dB-Hz	33.0 dB-Hz	

A.4 SUMMARY

Administrations should ensure that their GEOLUT antenna G/T value, when combined with the other losses, will provide a positive value for the link margin.

-END OF ANNEX A-

-END OF DOCUMENT-

Cospas-Sarsat Secretariat
700 de la Gauchetière West, Suite 2450, Montreal (Quebec) H3B 5M2 Canada
Telephone: +1 514 954 6761 Fax: +1 514 954 6750
Email: mail@cospas-sarsat.int
Website: www.cospas-sarsat.org
